

# NuevaStyle

The NuevaStyle from IMI Cornelius is the offspring of our famous Nueva tower. The NuevaStyle couples modern design with high quality materials and can be used for both postmix and premix systems. High impact brand appearance is ensured with this new tower.

## Key features include

- Innovative & flexible design
- High quality materials
- Varying branding panel options to suit differing environments
- Versatility - LCD lighting available
- Available with 5, 6 or 8-valves
- Compatible with our new Duette System and its energy saving internal heat exchanger technology



All information contained in this document is the property of IMI Cornelius and should not be passed to any third party without prior written consent.

© IMI Cornelius

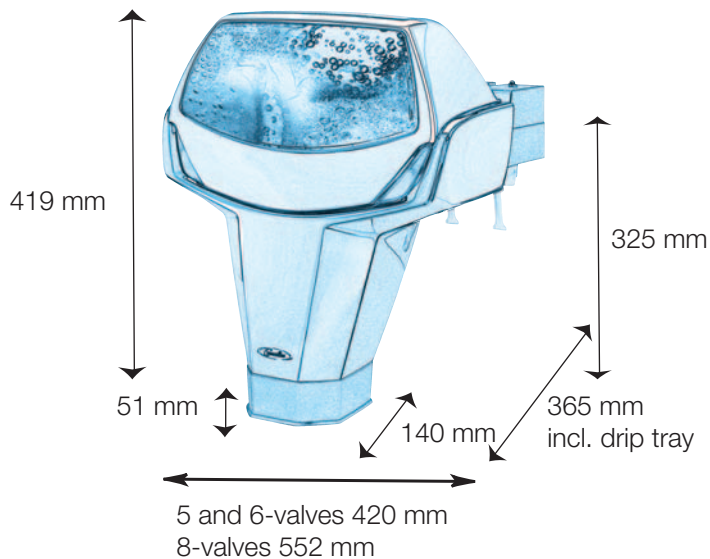

#### Technical data:

Number of taps:	5 - 8
Valve options:	Premix, SF1 or BT2000
Main supply for postmix, Dispense valves and illumination:	24 V / 50 Hz

#### Advertisement options:

Taxi-Sign Illuminated height incl. ad option	419 mm
LCD screen height incl. ad option Player for LCD Screen	419 mm
Sandblasted logo with flat cover Height incl. ad option	325 mm

**Drip tray 5 and 6-valves:**  
405x225x27 mm 14 9854 401

**Drip tray 8-valves:**  
605x225x27 mm 14 9854 601

#### Optional:

**Transformer**  
Standard type 100 VA, 230 V 14 1647 390

**Player**  
for LCD screen 14 1647 653

#### Variations and order numbers NuevaStyle

Please use the order form or contact us

#### Footprint:

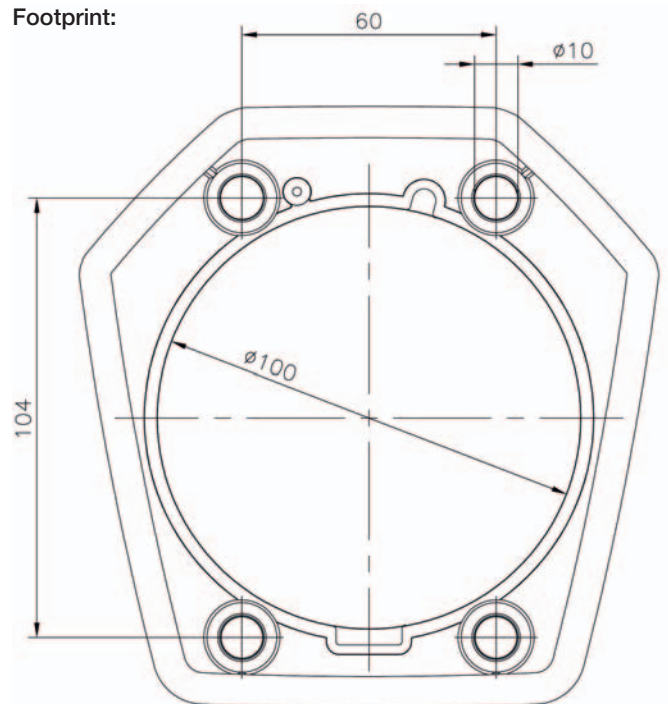

#### Product labels

The product labels for the respective valves are not included in the supply and can be ordered from the company Zeunert in Essen. Info at: [www.zeunert-schilder.de](http://www.zeunert-schilder.de)

IMI Cornelius reserves the right to modify the details in the publication as products and specifications are updated and improved. All data contained in this literature is correct at time of print. To ensure technical data is accurate please contact IMI Cornelius prior to placing your order.



#### United Kingdom

T: +44 (0) 870 905 0773  
F: +44 (0) 1142 320 067  
E: [customerservice@corneliusuk.com](mailto:customerservice@corneliusuk.com)  
[www.corneliusuk.com](http://www.corneliusuk.com)

#### Germany

T: +49 (0) 2173 793 0  
F: +49 (0) 2173 774 38  
E: [info@imi-cornelius.com](mailto:info@imi-cornelius.com)  
[www.imi-cornelius.com](http://www.imi-cornelius.com)

